



Broadcast Antennas



Antenna Product Catalogue

Skymasts Antennas Ltd, Equilibrium House, Mansion Close, Moulton Park Industrial Estate, Northampton, NN3 6RU, England.

T: +44(0)1604 494132 F: +44(0)1604 494133 E: info@skymasts.com W: www.skymasts.com

Skymasts Broadcast Antenna Catalogue

Code	Description	Frequency	Gain (dBd)	Page
S.1-98	FM Folded Dipole Antenna	88-108MHz	2 / 0	3
S.1H-98	Heavy Duty FM Folded Dipole Antenna	88-108MHz	2 / 0	4
S.3YH-98	Heavy Duty Three Element FM Yagi Antenna	88-108MHz	6	5
S.4YH-98	Heavy Duty Four Element FM Yagi Antenna	88-108MHz	7.5	6
S.EFX-98	FM Glassfibre End Fed Dipole	88-108MHz	0	7
470.04.33.00	DAB Dipole Antenna	208-235MHz	0	8
470.34.33.00	DAB Colinear Dipole Antenna	208-235MHz	3	9
S.LPA-98	FM Log Periodic Antenna	88-108MHz	6	10
S.LPA-675	UHF TV Log Periodic Antenna	468-870MHz	8	11
S.LBLAD	Lindenblad Mixed Polarisation FM Antenna	88-108MHz	0.5	12

The S.1 series are of a rugged and reliable construction. The one piece folded dipole incorporates a d.c. short to minimise static interference. The balun assembly is completely encapsulated in epoxy resin, totally preventing moisture ingress, and has been tested to BS5490:IP67. These antennas can be arranged in a variety of arrays in combination with MH power splitters to produce a wide range of radiation patterns. They are supplied as standard with 3m. of RG213 cable terminated with an 'N' type socket. Heavy duty and stainless steel options are available.

Electrical & mechanical specifications



Frequency range	88-108 MHz
Input impedance	50Ω
Bandwidth	± 10% of centre frequency
VSWR	<1.5:1
Front to back ratio	4 dB
Maximum input power	150 Watts
Polarisation	Vertical
Forward gain	2 dBd
3dB Beamwidth	E Plane 85° H Plane 200° (Gain & RPE assumes mount on conductive pole)
Standard connection	3m Length of RG 213 c/w 'N' type socket.
Elements	19.0mm dia.x 1.6mm wall aluminium alloy grade 6063T6
Support boom	31.7mm dia. x 2.6 mm wall aluminium alloy grade 6082T6
Fasteners	Stainless steel grade A2-70
Saddle clamps	Diecast zinc alloy
Insulator	Epoxy resin encapsulant
Lightning protection	Direct grounded
Mounting brackets	COP Series (not supplied)
Weight	2.9 kg
Dimensions	1m x 1.33 m
Wind loading @ 45m/s	167 N

Radiation patterns (mounted against pole)

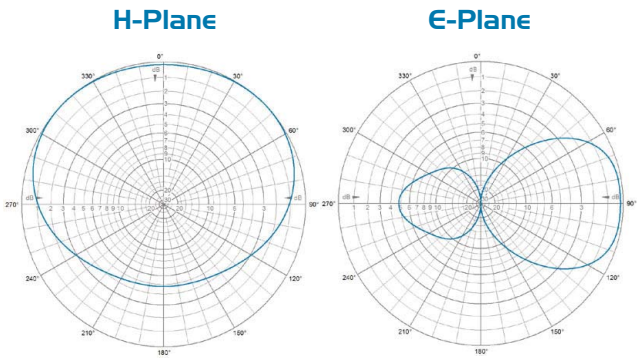

Mounting accessories

- 
271 Series
Cast aluminium cross clamp 30-60mm
- 
COP54
Galvanised steel cross clamp 32/50mm
- 
UA Series
Cast aluminium cross clamp 25-115mm

Standard stock models

Stock code	Frequency
S.I-78	70-86MHz
S.H27	117-137MHz
S.H65	155-175MHz
S.H84	176-192MHz
S.I-200	192-208MHz
S.I-405	380-430MHz
S.I-380-470	380-470MHz
S.I-445	420-470MHz

The S.1H Series are designed for use in extreme environments, or for multi channel applications. The one piece folded dipole assembly incorporates a d.c. short and is completely encapsulated in epoxy resin, totally preventing moisture ingress. A sleeve is welded to the dipole to increase strength, and improve VSWR. These antennas can be arranged in a variety of arrays to produce a wide range of radiation patterns. They are supplied as standard with 3m of RG213 cable terminated with an 'N' type socket.

Electrical & mechanical specifications



Frequency range	88-108 MHz
Input impedance	50Ω
Bandwidth	± 10% of centre frequency
VSWR	<1.5:1
Front to back ratio	4 dB
Maximum input power	500 Watts
Polarisation	Vertical
Forward gain	2 dBd
3dB Beamwidth	E Plane 85° H Plane 200° (Gain & RPE assumes mount on conductive pole)
Standard connection	3m Length of RG 213 c/w 'N' type socket.
Elements	19.0mm dia.x 1.6mm wall aluminium alloy grade 6063T6
Dipole sleeve (welded)	31.7mm dia. x 2.6mm wall aluminium alloy grade 6063T6
Support boom	48.4mm dia. x 4.5 mm wall aluminium alloy grade 6082T6
Fasteners	Stainless steel grade A2-70
Saddle clamps	Machined aluminium alloy
Insulator	Epoxy resin encapsulant
Lightning protection	Direct grounded
Mounting brackets	271 Series (not supplied)
Weight	5.3 kg
Dimensions	1m x 1.5 m
Wind loading @ 45m/s	202 N

Radiation patterns (mounted against pole)

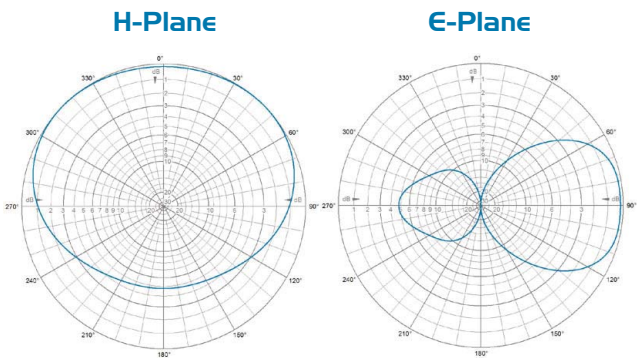

Mounting accessories

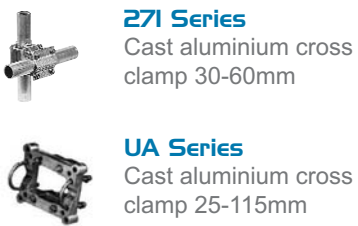

Standard stock models

Stock code	Frequency
S.IH-78	68-88MHz
S.IH-98	88-108MHz
S.IH-127	117-137MHz
S.IH-165	155-175MHz

The S.3YH Series are of a rugged and reliable construction for communication networks in the VHF band. The one piece folded dipole incorporates a d.c. short to minimise static interference. The balun assembly is completely encapsulated in epoxy resin, totally preventing moisture ingress, and has been tested to BS5490:IP67. These antennas give a gain of 6.0dBd with front to back ratio typically 15 dB. They are supplied as standard with 3 metres of RG213 cable terminated with an 'N' type socket, although cable and connector options are available upon request.

Electrical & mechanical specifications



Frequency range	88-108 MHz
Input impedance	50Ω
VSWR	<1.5:1
Front to back ratio	15 dB
Maximum input power (CW)	300 Watts, with 1,000 Watt option
Polarisation	Vertical or horizontal
Forward gain	6.0 dBd - (8.1dBi)
3dB Beamwidth	E Plane 65° H Plane 101°
Standard connection	3m Length of RG213 c/w 'N' type socket (other options available, 1/2" 'Superflex' cable - 7/16 connectors etc.)
Elements	19.0mm dia.x 1.6mm wall aluminium alloy grade 6063T6
Support boom	48.4 mm dia. x 4.5 mm wall aluminium alloy grade 6082T6
Fasteners	Stainless steel grade A2-70
Saddle clamps	Aluminium Alloy
Insulator	Epoxy resin encapsulant
Lightning protection	Direct grounded
Typical weight @100MHz	9.0kg
Typical length @100MHz	2.2
Typical wind loading @ 45m/s	300N

Free space radiation patterns

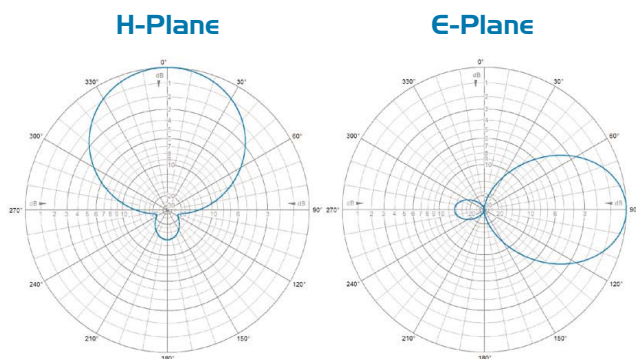

Mounting accessories

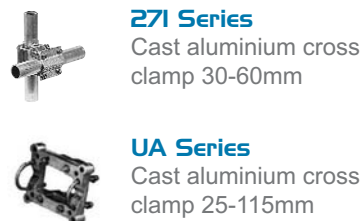

271 Series
Cast aluminium cross clamp 30-60mm

UA Series
Cast aluminium cross clamp 25-115mm

Standard stock models

Stock code	Frequency
S.3YH-98	88-108MHz
S.3YH-127	117-137MHz

The S.4YH Series are of a rugged and reliable construction for communication networks in the VHF band. The one piece folded dipole incorporates a d.c. short to minimise static interference. The balun assembly is completely encapsulated in epoxy resin, totally preventing moisture ingress, and has been tested to BS5490:IP67. These antennas give a gain of 7.5dBd with front to back ratio typically 15 dB. They are supplied as standard with 3 metres of RG214 cable terminated with an 'N' type socket, although cable and connector options are available upon request. This version has been designed for the Band II FM Broadcasting band and is available with either 300w or 1,000w capability.

Electrical & mechanical specifications

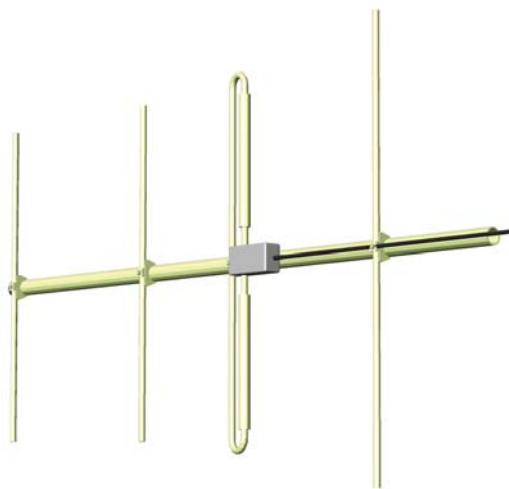

Frequency range	88 -108 MHz
Input impedance	50Ω
VSWR	<1.5:1 (typically <1.2:1 at specified frequency)
Front to back ratio	15 dB
Maximum input power (CW)	300 Watts, with 1,000 Watt option
Polarisation	Vertical or horizontal
Forward gain	7.5 dBd
3dB Beamwidth	E Plane 57° H Plane 74°
Standard connection	3m Length of RG214 c/w 'N' type socket, (optional 1/2" 'Superflex' cable and 7/16DIN connector)
Elements	19.0mm dia.x 1.6mm wall aluminium alloy grade 6063T6
Support boom	48.4 mm dia. x 4.5 mm wall aluminium alloy grade 6082T6
Fasteners	Stainless steel grade A2-70
Saddle clamps	Aluminium Alloy
Insulator	Epoxy resin encapsulant
Lightning protection	Direct grounded
Typical weight	10.1kg
Typical length	2.9
Typical wind loading @ 45m/s	357N

Free space radiation patterns

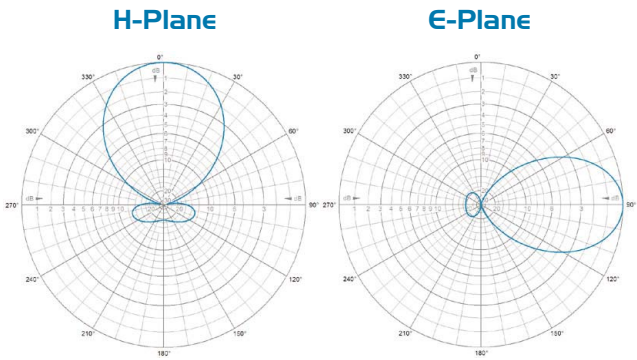

Mounting accessories

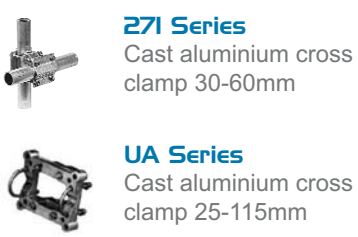

271 Series
Cast aluminium cross clamp 30-60mm

UA Series
Cast aluminium cross clamp 25-115mm

Standard stock models

Stock code	Frequency
S.4YH-98	88-108MHz
S.4YH-127	117-137MHz

The S.EFX series of glassfibre dipoles are designed for professional base station and fixed mobile applications. The antennas have been designed with an integral dual purpose mounting bracket, cast in aluminium. The stainless steel fittings enable the antennas to be fixed to the top or side of a vertical pole up to 60mm diameter. The centre fed dipole is fed via coaxial cable, giving a stable radiation pattern over a wide operating band. All S.EFX series are d.c. grounded. A VSWR of 1.5:1 is achieved over a bandwidth of $\pm 6\%$ of centre frequency.



Electrical & mechanical specifications

Frequency range	88-108 MHz (specify frequency)
Input impedance	50 Ω
Bandwidth	$\pm 6\%$ of centre frequency
VSWR	<1.5:1
H Plane ripple	< ± 0.5 dB
Maximum input power	150 Watts
Polarisation	Vertical
Forward gain	0 dBd
3 dB Beamwidth	E Plane 80°
Connection	0.5m Length of RG 213 c/w 'N' type socket.
Dipoles	11mm dia brass tube
Dipole feeds	PTFE dielectric coaxial cable
Shroud	Parallel grey glassfibre tube 40mm dia.
Lightning protection	Direct grounded
Mounting bracket	Integral diecast aluminium alloy grade LM6
Bracket finish	Black anodise
Mast fixings	Stainless steel M8 V bolts grade A2-70
Weight	1.5kg
Length	3.1m
Wind loading @ 45m/s	135N

Free space radiation patterns

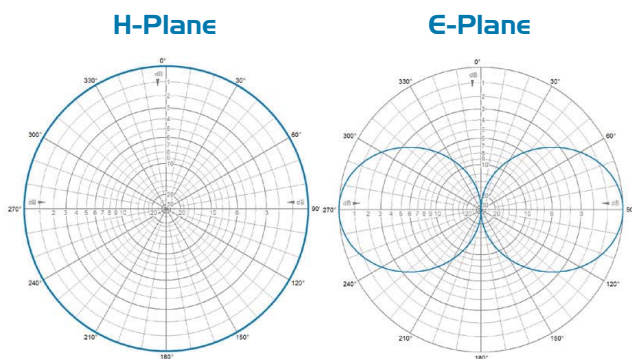

Mounting accessories



CSB
Welded
Aluminium
Colinear
Standoff

Standard stock models

Stock code	Frequency
S.EFX-127	117-137MHz
S.EFX-165	155-175MHz
S.EFX-184	176-192MHz
S.EFX-200	192-208MHz
S.EFX-395	380-410MHz
S.EFX-420	410-430MHz
S.EFX-445	420-470MHz
S.EFX-915	870-960MHz

The 470.04 Series of glassfibre dipoles are designed for high power DAB broadcast applications. The antennas are well suited to the most demanding applications both physically and environmentally, and have been engineered for optimal VSWR performance over the VHF DAB band. They have been designed with an integral mounting bracket, cast in aluminium, which enables the 470 to be fitted directly on a vertical pole of 50mm diameter. The aluminium centre fed dipole is fed via PTFE coaxial cable and offers a stable radiation pattern over a wide operating band. The antenna is available in a variety of two part lacquer finishes, including IR proof military green.

Electrical & mechanical specifications



Frequency range	208 - 235 MHz
Input impedance	50Ω
VSWR	<1.25:1
H Plane ripple	< ±1dB
Maximum input power	1.5kW
Polarisation	Vertical
Antenna gain	0 dBd
3dB Beamwidth	E Plane 80°
Connection	7/16 DIN socket
Dipole	120mm dia. aluminium rolled tube
Dipole feed	PTFE dielectric coaxial cable
Shroud	Parallel white glassfibre tube 128mm
Lightning protection	Direct grounded
Mounting bracket	Integral sandcast aluminium alloy grade LM6 to suit 50mm dia. support pole
Mast fixings	Stainless steel M10 bolts grade A2-70
Weight	4.7 kg
Length	1.2 m
Typical Wind loading @ 45m/s	184 N

Free space radiation patterns

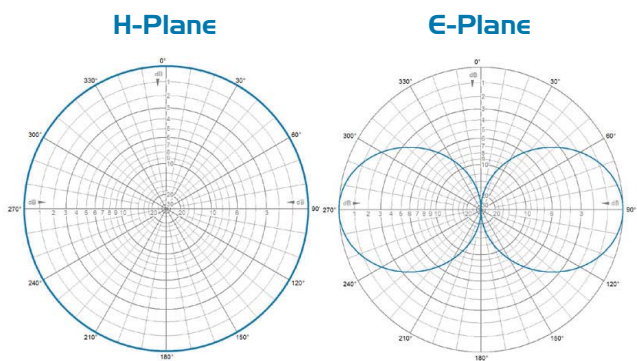

Mounting accessories

-  **2140/2141 Series**
Galvanised steel parallel clamp up to 60/120mm
-  **UA66-22**
Cast aluminium cross / parallel clamp 25-50mm
- ATS**
Aluminium Tube 1 29/32" x 7g

Standard stock models

Stock code	Frequency
470.01.05.00	108-175MHz
470.31.05.00	108-175MHz
470.02.05.00	225-400MHz
470.32.05.00	225-400MHz
470.05.05.00	100-400MHz
470.04.33.00	208-235MHz
470.34.33.00	208-235MHz

The 470.34 Series of glassfibre dipoles are designed for high power DAB broadcast applications. The antennas are well suited to the most demanding applications both physically and environmentally, and have been engineered for optimal VSWR performance over the VHF DAB band. The 470.34 offers 3dBd gain and is supplied with an integral mounting bracket, in aluminium, which enables the 470 to be fitted directly on a vertical pole of 76mm diameter. The aluminium centre fed dipole is fed via PTFE coaxial cable and offers a stable radiation pattern over a wide operating band. The antenna is available in a variety of two part lacquer finishes, including IRR military green.

Electrical & mechanical specifications



Frequency range	208 - 235 MHz
Input impedance	50Ω
VSWR	<1.25:1
H Plane ripple	< ±1dB
Maximum input power	1.5kW
Polarisation	Vertical
Antenna gain	3 dBd
3dB Beamwidth	E Plane 40°
Connection	7/16 DIN socket
Dipole	120mm dia. aluminium rolled tube
Dipole feed	PTFE dielectric coaxial cable
Shroud	Parallel white glassfibre tube 128mm
Lightning protection	Direct grounded
Mounting bracket	Integral aluminium alloy to suit 76mm dia. support pole or 2" tube mount
Mast fixings	Stainless steel M10 bolts grade A2-70
Weight	6 kg
Length	2.3 m
Typical Wind loading @ 45m/s	438 N

Free space radiation patterns

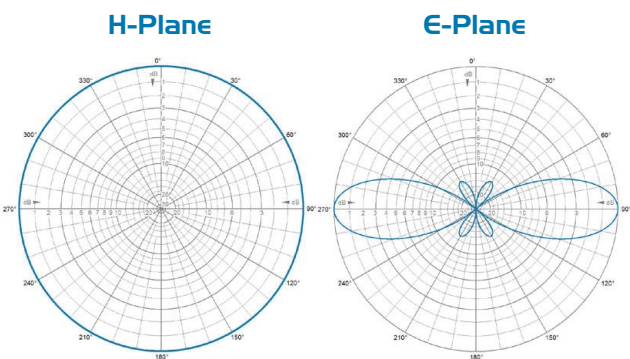

Mounting accessories

Standard stock models

Stock code	Frequency
470.01.05.00	108-175MHz
470.31.05.00	108-175MHz
470.02.05.00	225-400MHz
470.32.05.00	225-400MHz
470.05.05.00	100-400MHz
470.04.33.00	208-235MHz
470.34.33.00	208-235MHz

The S.LPA-98 has a heavy duty construction for VHF FM band transmission and reception. The wideband antenna features excellent side and back lobe suppression and constant performance over the full band. The antenna can be mounted for vertical or horizontal polarisation and give a gain of 8dBi with front to back ratio typically 18 dB. They are terminated as standard with a 7/16 type socket, although connector options are available upon request.

Electrical & mechanical specifications

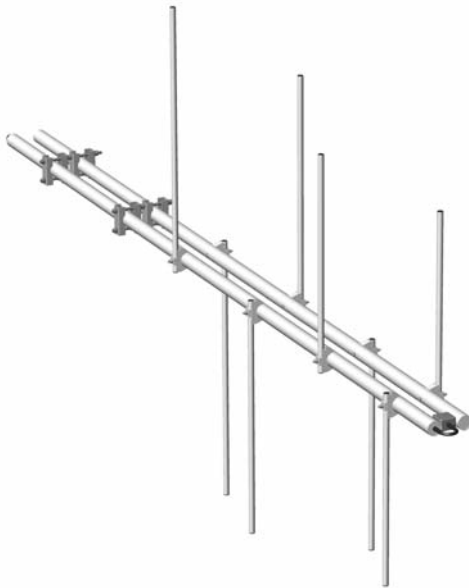

Frequency range	87.5-108 MHz
Input impedance	50Ω
VSWR	<1.4:1
Front to back ratio	18 dB
Maximum input power (CW)	S.LPA-98 500 Watts S.LPAH-98 2000 Watts
Polarisation	Vertical or horizontal
Forward gain	8.0 dBi
3dB Beamwidth	E Plane 55° H Plane 110°
Standard connection	7/16 DIN Female
Elements	19.0mm dia.x 1.6mm wall aluminium alloy grade 6063T6
Support boom	48.4 mm dia. x 4.5 mm wall aluminium alloy grade 6082T6
Fasteners	Stainless steel grade A2-70
Saddle clamps	Aluminium Alloy
Insulator	Epoxy resin encapsulant
Lightning protection	Direct grounded
Weight	16kg
Dimensions	Length 3.3m, maximum height 1.75m
Typical wind loading @ 45m/s	640N

Free space radiation patterns

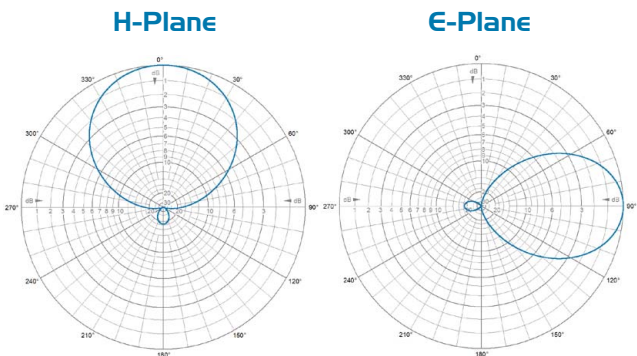

Mounting accessories

- 

UA 66-24
Cast aluminium cross clamp 25-115mm
- 

UA 64-23
Cast aluminium cross clamp 25-50-75mm

Standard stock models

Stock code	Frequency
S.LPA-98	87.5-108MHz
S.LPA-I18	118-162MHz
S.LPA-225	225-400MHz
S.LPA-675	468-870MHz

The S.LPA-675 Antenna is a heavy duty log periodic type antenna for use with band IV/V analogue and digital TV transmission and reception. The wideband antenna features excellent side and back lobe suppression and constant performance over the full band. The antenna can be mounted for vertical or horizontal polarisation and can be supplied with a 7/16 DIN or 'N' type connector. It is constructed from aluminium booms and elements featuring alocrom treatment to enhance antenna's durability.

Electrical & mechanical specifications

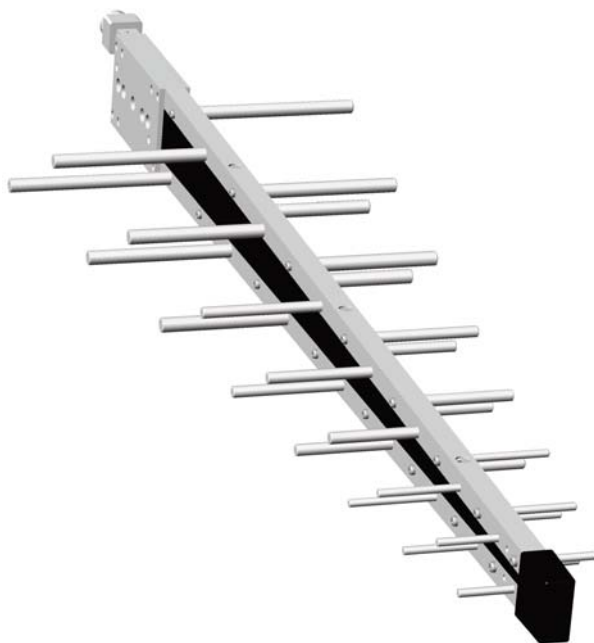

Frequency range	468 - 870MHz
Input impedance	50Ω
VSWR	<1.3:1
Front to back ratio	20 dB
Input power	250 Watts mean
Polarisation	Vertical & horizontal
Forward gain	10dBi
3 dB Beamwidth	E Plane 53° H Plane 68°
Standard connection	7/16 DIN Socket
Elements	Aluminium rod 1/2", 3/8" and 1/4" diameters
Support booms	Aluminium box tube 3/4" x 16g
Protection	Alocrom 1000
Fasteners	Stainless steel grade A2-70
Insulator	LDPE
Lightning protection	Direct grounded
Weight	3 kg
Dimensions	1210 x 320 x 90mm

Free space radiation patterns

H-Plane

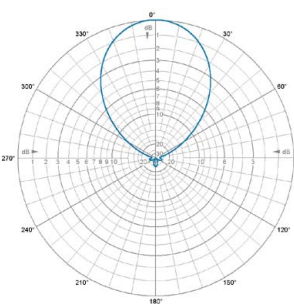

E-Plane

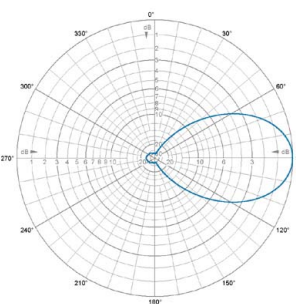

Mounting accessories

Standard stock models

Stock code	Frequency
S.LPA-98	87.5-108MHz
S.LPA-118	118-162MHz
S.LPA-225	225-400MHz
S.LPA-675	468-870MHz

The S.LBLAD array is designed for mixed polarisation broadcast on FM radio systems. The array consists of four folded dipoles affixed to a rugged mounting bracket, fed in phase from a machined power splitter, to achieve an omnidirectional mixed polarisation antenna. The arrays give a maximum gain of 0.5dBd, and can be stacked to achieve higher gain, a narrower beam or multiple transmissions. The balun assembly is completely encapsulated in epoxy resin, totally preventing moisture ingress, and has been tested to BS5490:IP67. The power splitter / array input is terminated standard with an 'N' type female, although cable and connector options are available upon request.

Electrical & mechanical specifications



Frequency range	88 - 108 MHz
Bandwidth	Optimised for single transmit frequency
Input impedance	50Ω
VSWR	<1.2:1
Maximum input power	250W
Polarisation	Mixed / Circular
Forward gain	0.5 dBd
3dB Beamwidth	E Plane 65° H Plane 360°
Standard connection	N socket
Elements	19.0mm dia.x 1.6mm wall aluminium alloy grade 6063T6
Element support boom	31.7 mm dia. x 2.6 mm wall aluminium alloy grade 6082T6
Fasteners	Stainless steel grade A2-70
Saddle clamps	Diecast zinc alloy
Insulator	Epoxy resin encapsulant
Lightning protection	Direct grounded
Mounting bracket	Welded flange bracket to suit 50mm support pole
Typical weight	17kg

Free space radiation patterns

H-Plane

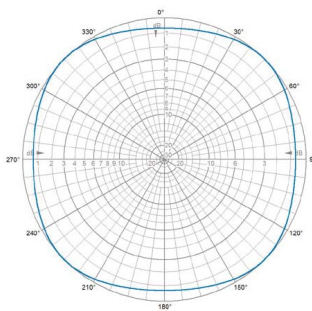

E-Plane

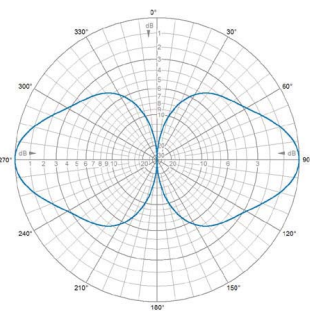

Mounting accessories

Standard stock models

Stock code | **Frequency**

Manufactured to requirements



This product is RoHS compliant